



Valla®



VALLA 20 E MOBILE CRANE MAX CAPACITY 2 t



PROPULSION: 2 kW - 24 V AC fanned reversible electric motor fitted with electronic speed control. Disk brake on drive wheel electrically operated. Equipped with dead man cut out. Reduction between motor and wheel by gears in oil bath. Max speed 3,5 Km/h.

BATTERY: Ah 345 - V 24, battery meter on dashboard.

STEERING: by steering helm. Allowing 180° steering. Built in safety device in reverse gear.

CRANE FRAME: fabricated from preformed and welded steel plate with built-in counterweight.

BOOM: fabricated from preformed and welded steel plate with 2 hydraulic telescoping sections fitted with adjustable nylon wear pads and manual extension.

WHEELS: rear 1 cushion 300 x 138. Front 2 solid tires 16 x 6 - 8".

HYDRAULIC SYSTEM: in own enclosed circuit powered by a 2 kW - 24 V motor driven pump through two self cancelling control valves, lever operated, 1 for boom raise and lower, 1 for boom extending and retraction. Fitted with safety valves and filters. Maximum hydraulic pressure 180 Bar.

TOTAL MACHINE WEIGHT: 1.950 Kg.

OPTIONAL EXTRAS: L.M.I. (Electronic Load Moment Indicator), manual jib extension, man bucket, remote control, hydraulic winch, hydraulic chain hoist, carry deck, battery, battery charger and non-marking tires.

Valla S.p.A.

Via Piacenza, 45 - 29010 Calendasco - Piacenza - ITALIA
Tel. 0039 0523 762025 - 762004 - Fax 0039 0523 760531
Internet: www.valla.com - email: info@valla.com

The crane complies with following international standards:

- I.S.P.E.S.L.
- DIN 15018 (1,3) - 15019 (1) Class H2 B3
- ANSI - 1994
- 98/37/CE
- 89/336/CEE

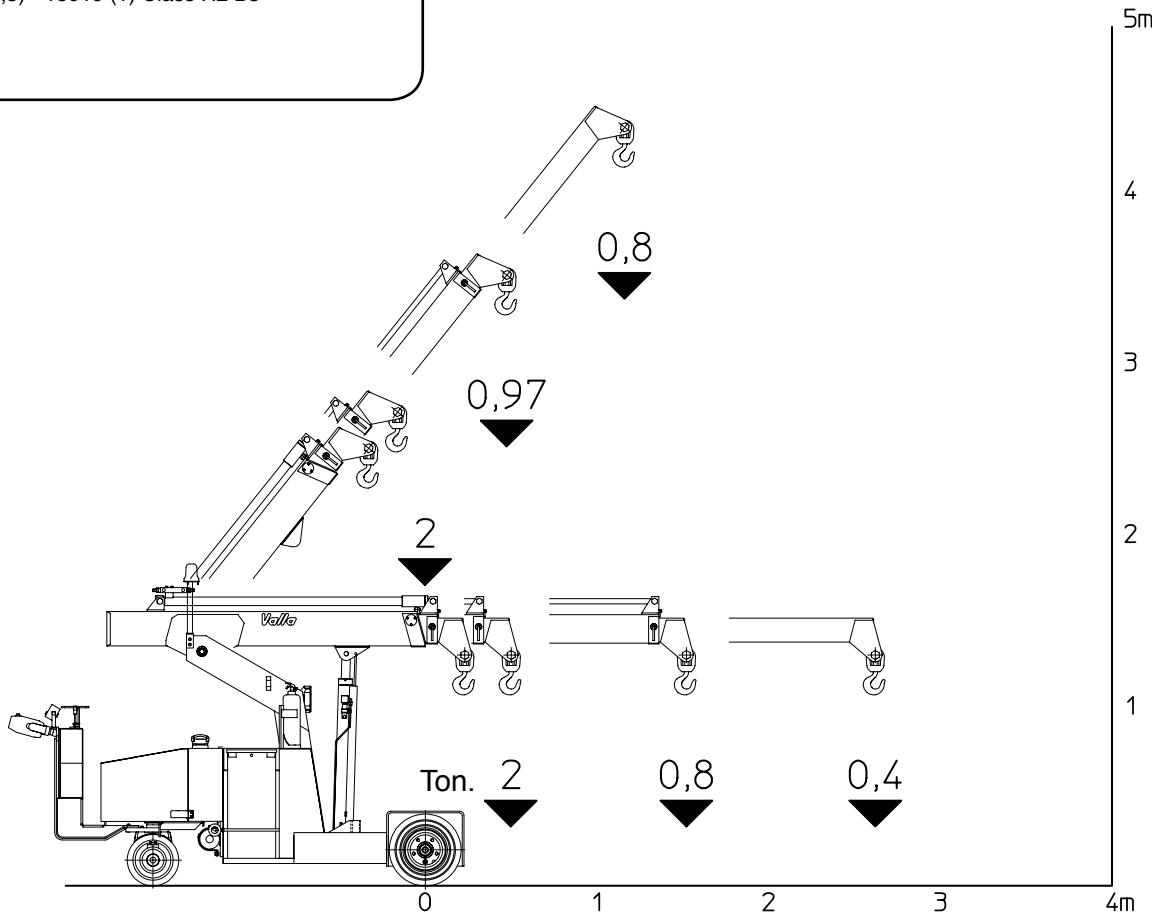

VALLA MODEL 20 E

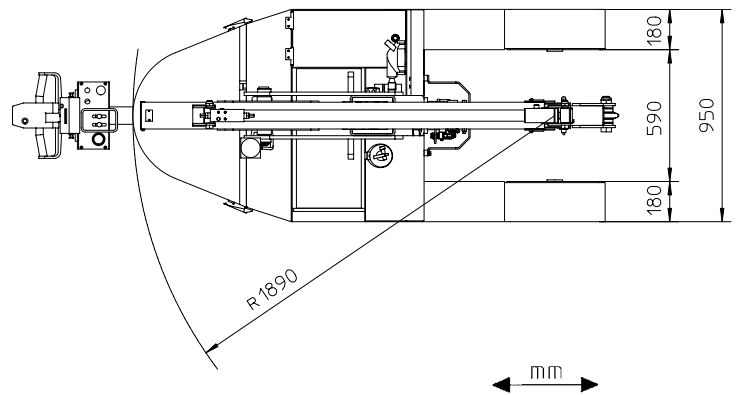
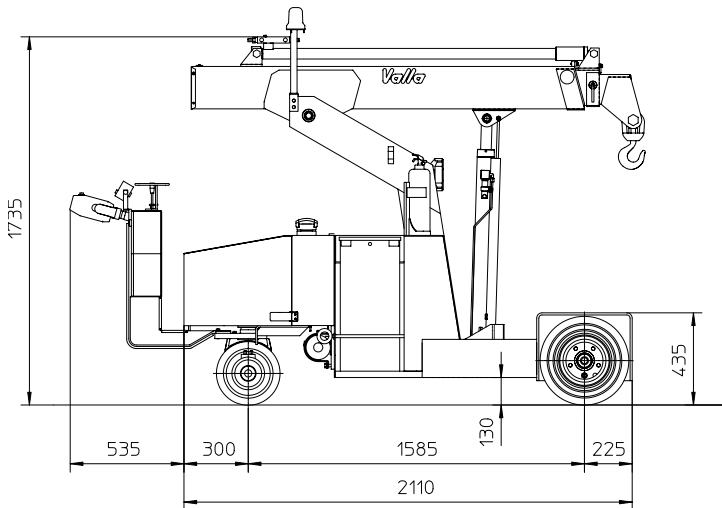

Valla S.p.A.

Via Piacenza, 45 - 29010 Calendasco - Piacenza - ITALIA
 Tel. 0039 0523 762025 - 762004 - Fax 0039 0523 760531
 Internet: www.valla.com - email: info@valla.com

